



**Reading Materials for
IC Training Modules**

Computer Numerical Control (CNC)

IC PROFESSIONAL TRAINING SERIES

Last updated at AUGUST 2009

Copyright reserved by INDUSTRIAL CENTRE, THE HONG KONG POLYTECHNIC UNIVERSITY

Computer Numerical Control (CNC)

Objectives:

- ✓ To understand the working principle and applications of CNC machines.
- ✓ To be able to prepare CNC part programmes for machining 2-D workpieces.
- ✓ To understand the structure and flow of a CAM system.

Content:

Chapter 1	Numerical Control Fundamentals
Chapter 2	CNC Part Programming
Chapter 3	Computer Aided Manufacturing

Introduction

Computer Numerical Control (CNC) is a specialized and versatile form of Soft Automation and its applications cover many kinds, although it was initially developed to control the motion and operation of machine tools.

Computer Numerical Control may be considered to be a means of operating a machine through the use of discrete numerical values fed into the machine, where the required 'input' technical information is stored on a kind of input media such as floppy disk, hard disk, CD ROM, DVD, USB flash drive, or RAM card etc. The machine follows a predetermined sequence of machining operations at the predetermined speeds necessary to produce a workpiece of the right shape and size and thus according to completely predictable results. A different product can be produced through reprogramming and a low-quantity production run of different products is justified.



Fig.1-1 CNC Machine Centre (Courtesy of Agie Charmilles)

The definition of CNC given by Electronic Industry Association (EIA) is as follows:

A system in which actions are controlled by the direct insertion of numerical data at some point. The system must automatically interpret at least some portion of this data.

In a simple word, a CNC system receives numerical data, interpret the data and then control the action accordingly.

Chapter 1. Computer Numerical Control Fundamentals

Objectives:

- ✓ To understand the working principle of CNC machines.
- ✓ To understand the characteristics of the driving systems.
- ✓ To understand the characteristics of the feedback devices.
- ✓ To understand the applications of CNC machines.

1.1 Control Systems

1.1.1 Open Loop Systems

Open loop systems have no access to the real time data about the performance of the system and therefore no immediate corrective action can be taken in case of system disturbance. This system is normally applied only to the case where the output is almost constant and predictable. Therefore, an open loop system is unlikely to be used to control machine tools since the cutting force and loading of a machine tool is never a constant. The only exception is the wirecut machine for which some machine tool builders still prefer to use an open loop system because there is virtually no cutting force in wirecut machining.

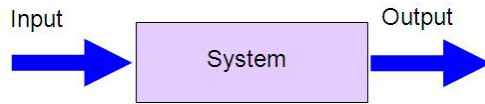

Fig.1-2(a) Block Diagram of an Open Loop System

1.1.2 Close Loop Systems

In a close loop system, feed back devices closely monitor the output and any disturbance will be corrected in the first instance. Therefore high system accuracy is achievable. This system is more powerful than the open loop system and can be applied to the case where the output is subjected to frequent change. Nowadays, almost all CNC machines use this control system.

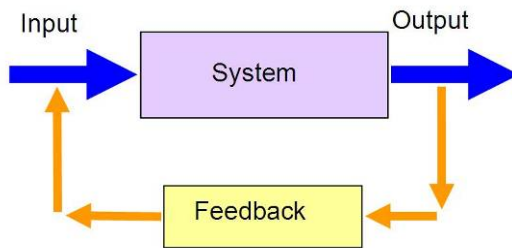

Fig.1-2(b) Block Diagram of a Close Loop System

1.2 Elements of a CNC System

A CNC system consists of the following 6 major elements:

- a. Input Device
- b. Machine Control Unit
- c. Machine Tool
- d. Driving System
- e. Feedback Devices
- f. Display Unit

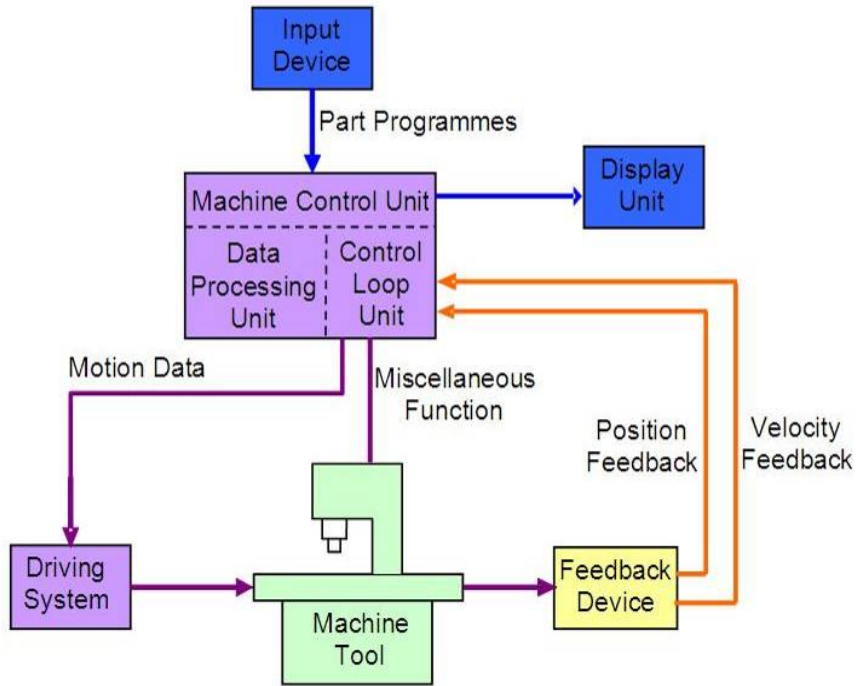

Fig.1-3 Working Principles of CNC Machines

1.2.1 Input Devices

a. Floppy Disk Drive

Floppy disk is a small magnetic storage device for CNC data input. It has been the most common storage media up to the 1970s, in terms of data transfer speed, reliability, storage size, data handling and the ability to read and write. Furthermore, the data within a floppy could be easily edited at any point as long as you have the proper program to read it. However, this method has proven to be quite problematic in the long run as floppies have a tendency to degrade alarmingly fast and are sensitive to large magnetic fields and as well as the dust and scratches that usually existed on the shop floor.



Fig.1-4 Floppy Disk Drive on a CNC machine

b. USB Flash Drive

A USB flash drive is a removable and rewritable portable hard drive with compact size and bigger storage size than a floppy disk. Data stored inside the flash drive

are impervious to dust and scratches that enable flash drives to transfer data from place to place. In recent years, all computers support USB flash drives to read and write data that make it become more and more popular in CNC machine control unit.

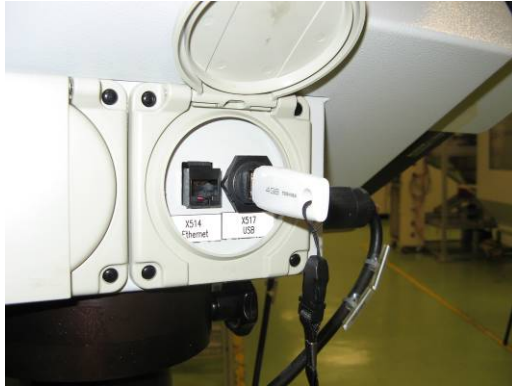

Fig.1-5 USB Flash Drive on a CNC machine

c. Serial communication

The data transfer between a computer and a CNC machine tool is often accomplished through a serial communication port. International standards for serial communications are established so that information can be exchanged in an orderly way. The most common interface between computers and CNC machine tools is referred to the EIA Standard RS-232. Most of the personal computers and CNC machine tools have built in RS232 port and a standard RS-232 cable is used to connect a CNC machine to a computer which enables the data transfer in reliable way. Part programs can be downloaded into the memory of a machine tool or uploaded to the computer for temporary storage by running a communication program on the computer and setting up the machine control to interact with the communication software.



Fig.1-6 Serial communication port on a CNC machine

Direct Numerical Control is referred to a system connecting a set of numerically controlled machines to a common memory for part program or machine program storage with provision for on-demand distribution of data to the machines. (ISO 2806:1980) The NC part program is downloaded a block or a section at a time into

the controller. Once the downloaded section is executed, the section will be discarded to leave room for other sections. This method is commonly used for machine tools that do not have enough memory or storage buffer for large NC part programs.

Distributed Numerical Control is a hierarchical system for distributing data between a production management computer and NC systems. (ISO 2806:1994) The host computer is linked with a number of CNC machines or computers connecting to the CNC machines for downloading part programs. The communication program in the host computer can utilize two-way data transfer features for production data communication including: production schedule, parts produced and machine utilization etc.

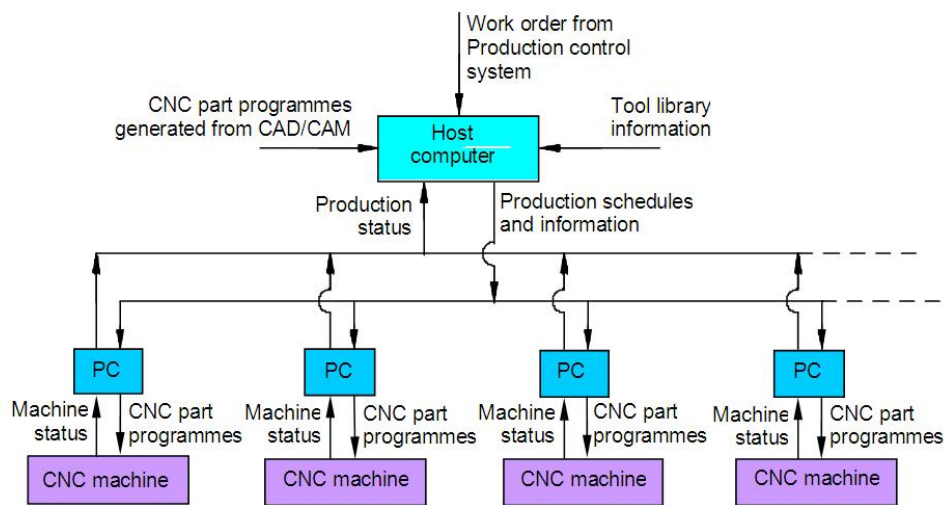

Fig.1-7 Serial communication in a Distributed Numerical Control system

d. Ethernet communication

Due to the advancement of the computer technology and the drastic reduction of the cost of the computer, it is becoming more practical and economic to transfer part programmes between computers and CNC machines via an Ethernet communication cable. This media provides a more efficient and reliable means in part programme transmission and storage. Most companies now built a Local Area Network (LAN) as their infrastructure. More and more CNC machine tools provide an option of the Ethernet Card for direct Machine communication within the LAN.



Fig.1-8 Ethernet port on a CNC machine

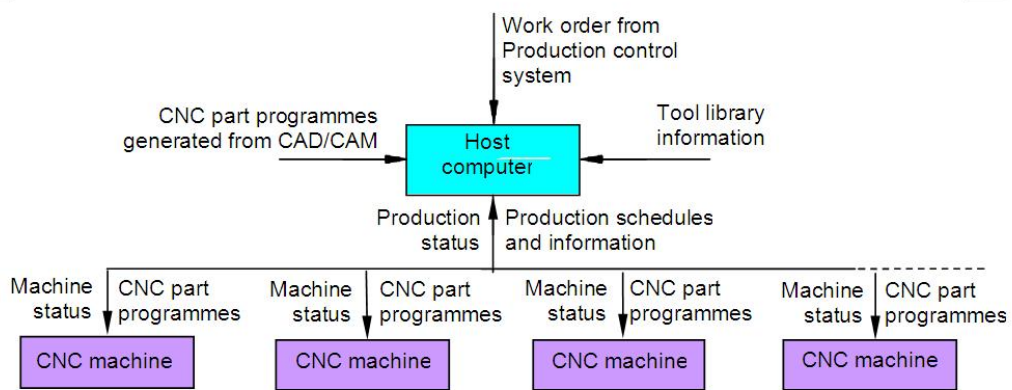

Fig.1-9 Ethernet network in a Distributed Numerical Control system

e. Conversational Programming

Part programmes can be input to the controller via the keyboard. Built-in intelligent software inside the controller enables the operator to enter the required data step by step. This is a very efficient way for preparing programmes for relatively simple workpieces involving up to 2½ axis machining.

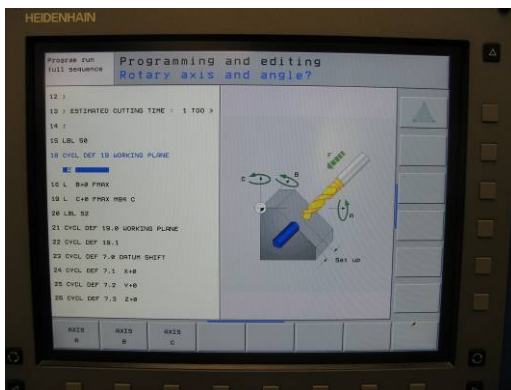

Fig.1-10 Conversational Programming in a CNC controller

1.2.2 Machine Control Unit (MCU)

The machine control unit is the heart of the CNC system. There are two sub-units in the machine control unit: the Data Processing Unit (DPU) and the Control Loop Unit (CLU).

a. Data Processing Unit

On receiving a part programme, the DPU firstly interprets and encodes the part programme into internal machine codes. The interpolator of the DPU then calculate the intermediate positions of the motion in terms of BLU (basic length unit) which is the smallest unit length that can be handled by the controller. The calculated data are passed to CLU for further action.

b. Control Loop Unit

The data from the DPU are converted into electrical signals in the CLU to control the driving system to perform the required motions. Other functions such as machine spindle ON/OFF, coolant ON/OFF, tool clamp ON/OFF are also controlled by this unit according to the internal machine codes.

1.2.3 Machine Tool

This can be any type of machine tool or equipment. In order to obtain high accuracy and repeatability, the design and make of the machine slide and the driving leadscrew of a CNC machine is of vital importance. The slides are usually machined to high accuracy and coated with anti-friction material such as PTFE and Turcite in order to reduce the stick and slip phenomenon. Large diameter recirculating ball screws are employed to eliminate the backlash and lost motion. Other design features such as rigid and heavy machine structure; short machine table overhang, quick change tooling system, etc also contribute to the high accuracy and high repeatability of CNC machines.



Fig.1-11(a) Ball Screw in a CNC machine

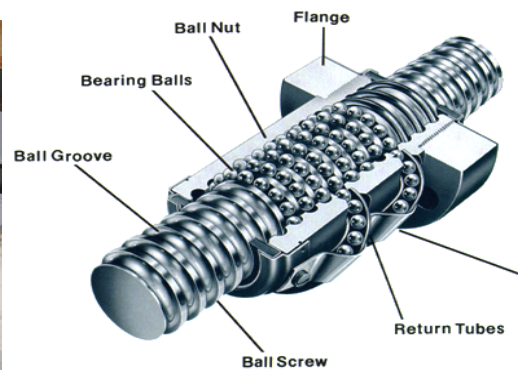

Fig.1-11(b) Ball screw structure

1.2.4 Driving System

The driving system is an important component of a CNC machine as the accuracy and repeatability depend very much on the characteristics and performance of the driving system. The requirement is that the driving system has to response accurately according to the programmed instructions. This system usually uses electric motors although hydraulic motors are sometimes used for large machine tools. The motor is coupled either directly or through a gear box to the machine leadscrew to moves the machine slide or the spindle. Three types of electrical motors are commonly used.

a. DC Servo Motor

This is the most common type of feed motors used in CNC machines. The principle of operation is based on the rotation of an armature winding in a permanently energised magnetic field. The armature winding is connected to a commutator, which is a cylinder of insulated copper segments mounted on the shaft. DC current is passed to the commutator through carbon brushes, which are connected to the machine terminals. The change of the motor speed is by varying the armature voltage and the control of motor torque is achieved by controlling the motor's armature current. In order to achieve the necessary dynamic behaviour it is operated in a closed loop system equipped with sensors to obtain the velocity and position feedback signals.

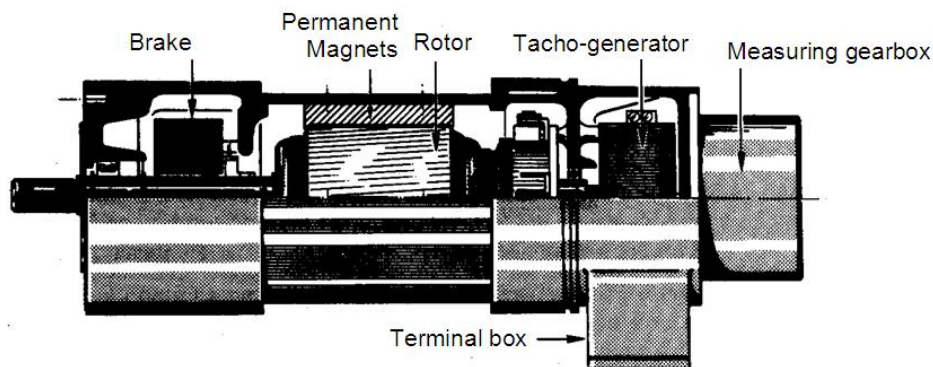

Fig.1-12 DC Servo Motor (Courtesy of Flexible Automation)

b. AC Servo Motor

In an AC servomotor, the rotor is a permanent magnet while the stator is equipped with 3-phase windings. The speed of the rotor is equal to the rotational frequency of the magnetic field of the stator, which is regulated by the frequency converter.

AC motors are gradually replacing DC servomotors. The main reason is that there is no commutator or brushes in AC servomotor so that maintenance is virtually not required. Furthermore, AC servos have a smaller power-to-weight ratio and faster response.

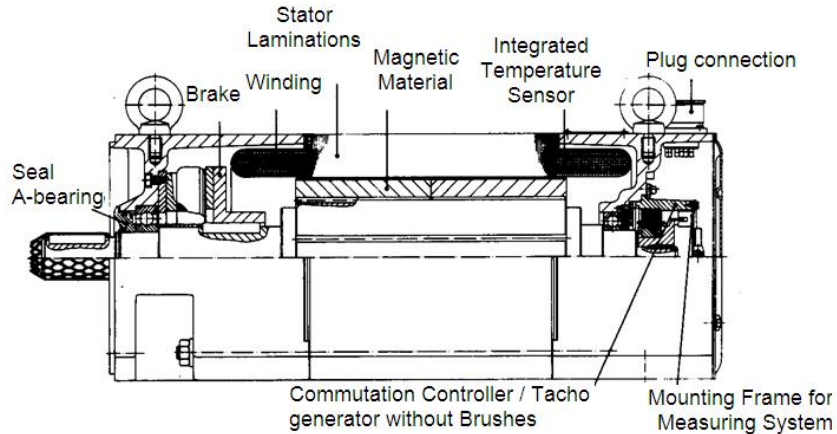

Fig.1-13 AC Servo Motor (Courtesy of Flexible Automation)

c. Stepping Motor

A stepping motor is a device that converts the electrical pulses into discrete mechanical rotational motions of the motor shaft. This is the simplest device that can be applied to CNC machines since it can convert digital data into actual mechanical displacement. It is not necessary to have any analog-to-digital converter nor feedback device for the control system. They are ideally suited to open loop systems.

However, stepping motors are not commonly used in machine tools due to the following drawbacks: slow speed, low torque, low resolution and easy to slip in case of overload. Examples of stepping motor application are the magnetic head of floppy-disc drive and hard disc drive of computer, daisy-wheel type printer, X-Y tape control, and CNC EDM Wire-cut machine.

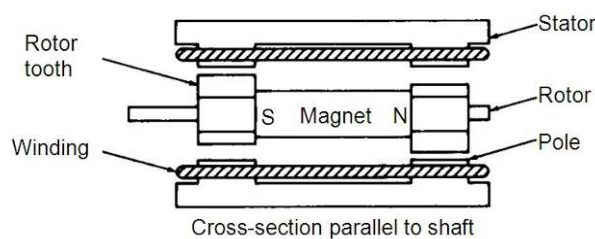

Fig.1-14 Stepping Motor (Courtesy Real-Time Microcomputer)

d. Linear Motor

A linear electric motor is an AC rotary motor laid out flat. The same principle used to produce torque in rotary motors is used to produce force in linear motors. Through the electromagnetic interaction between a coil assembly and a permanent magnet assembly, the electrical energy is converted to linear mechanical energy to generate a linear motion. As the motion of the motor is linear instead of rotational, therefore it is called linear motor. Linear motors have the advantages of high speeds, high precision and fast response. In the 1980s,

machine tool builders started using linear motors with the common motion control servo drives in the machine tool design.

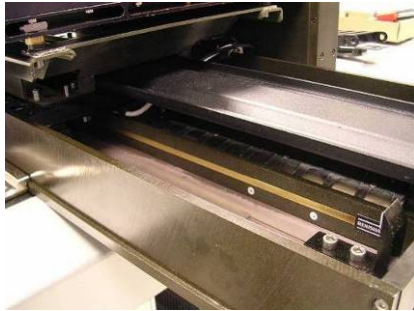

Fig.1-15 Linear Motor (Courtesy of Renishaw)

Among different designs of linear motors, permanent magnet brushless motors demonstrate a high force density, high maximum speed, and stable force constant. The lack of a brushed commutator assembly has the advantages of fewer maintenance, higher reliability and better smoothness.

An iron core brushless linear motor is similar to a conventional brushless rotary motor slit axially and then rolled out flat. The unrolled rotor is a stationary plate consisting of magnets tiled on an iron back plate and the unrolled stator is a moving coil assembly consisting of coils wound around a laminated steel core. Coil windings are typically connected in conventional 3 phase arrangement and commutation is often performed by Hall-effect sensors or sinusoidal. It has high efficiency and good for continuous force.

An ironless linear motor consists of a stationary U shaped channel filled with permanent magnets tiled along both interior walls. A moving coil assembly traverses between two opposing rows of magnets. Commutation is done electronically either by Hall-effect sensors or sinusoidal. The ironless linear motor has the advantages of lower core mass, lower inductance and no cogging for smooth motion as the ironless motors have no attractive force between the frameless components.

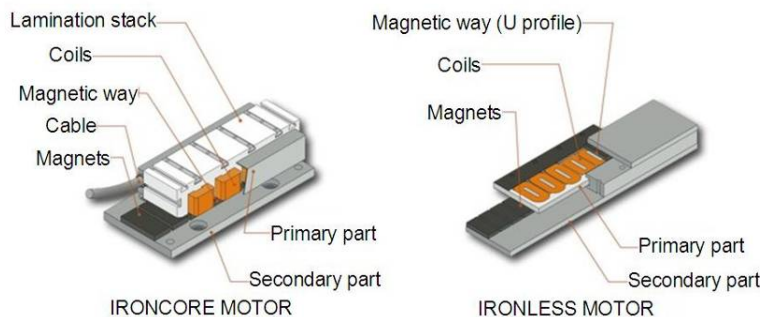

Fig.1-16 Ironcore and Ironless Linear Motor (Courtesy of ETEL)

1.2.5 Feedback Device

In order to have a CNC machine operating accurately, the positional values and speed of the axes need to be constantly updated. Two types of feed back devices are normally used, positional feed back device and velocity feed back device.

a. Positional Feed Back Devices

There are two types of positional feed back devices: linear transducer for direct positional measurement and rotary encoder for angular or indirect linear measurement.

Linear Transducers - A linear transducer is a device mounted on the machine table to measure the actual displacement of the slide in such a way that backlash of screws; motors, etc would not cause any error in the feed back data. This device is considered to be of the highest accuracy and also more expensive in comparison with other measuring devices mounted on screws or motors.

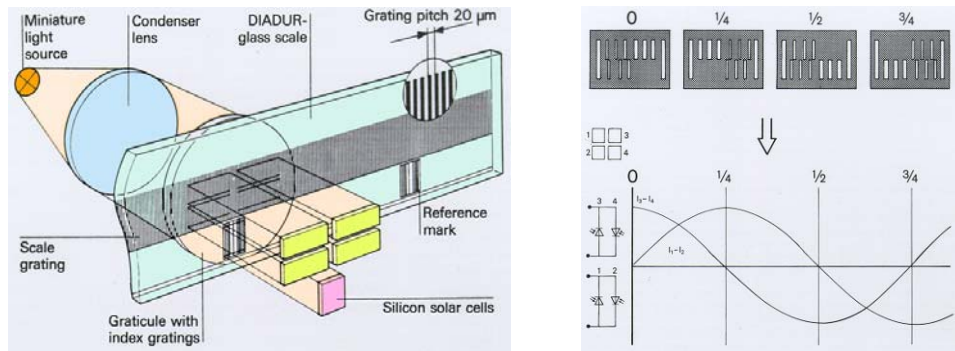

Fig.1-17 Linear Transducer (Courtesy of Heidenhain)

Rotary Encoders - A rotary encoder is a device mounted at the end of the motor shaft or screw to measure the angular displacement. This device cannot measure linear displacement directly so that error may occur due to the backlash of screw and motor etc. Generally, this error can be compensated for by the machine builder in the machine calibration process.

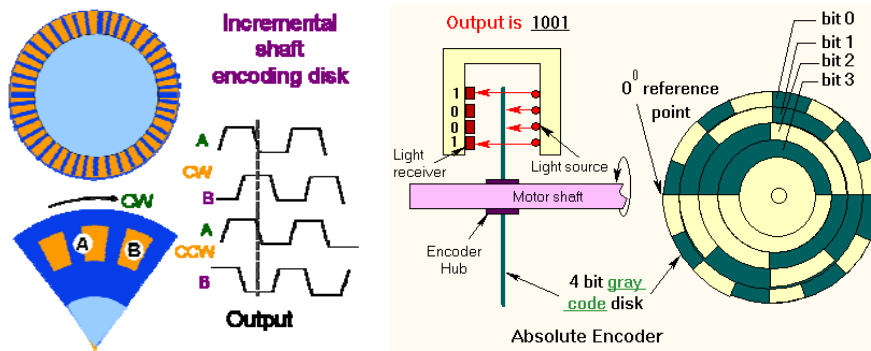

Fig.1-18 Incremental and Absolute Rotary Encoder

b. Velocity Feedback Device

The actual speed of the motor can be measured in terms of voltage generated from a tachometer mounted at the end of the motor shaft. DC tachometer is essentially a small generator that produces an output voltage proportional to the speed. The voltage generated is compared with the command voltage corresponding to the desired speed. The difference of the voltages can be then used to actuate the motor to eliminate the error.

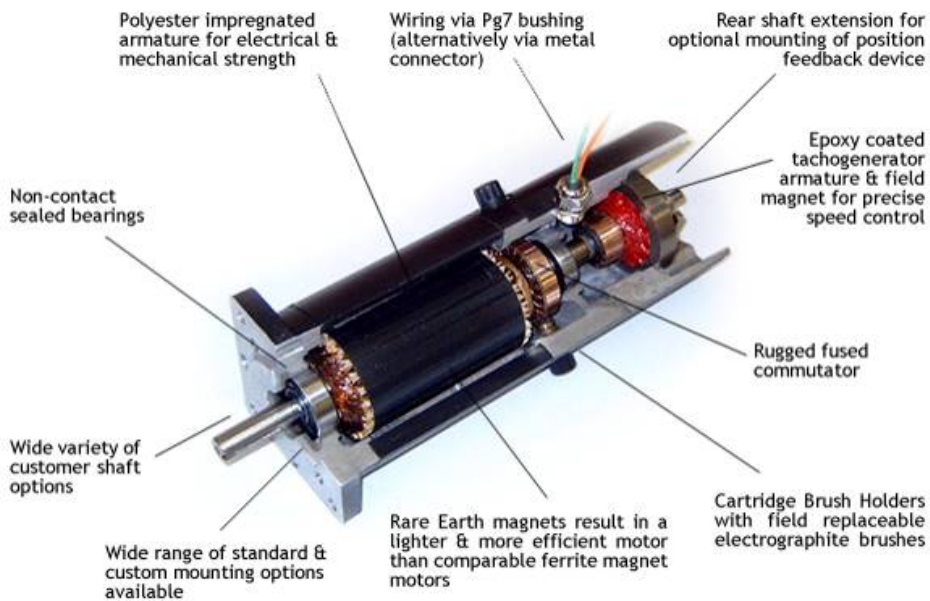

Fig.1-19 Tachogenerator (Courtesy of Callan)

1.2.6 Display Unit

The Display Unit serves as an interactive device between the machine and the operator. When the machine is running, the Display Unit displays the present

status such as the position of the machine slide, the spindle RPM, the feed rate, the part programmes, etc.

In an advanced CNC machine, the Display Unit can show the graphics simulation of the tool path so that part programmes can be verified before the actually machining. Much other important information about the CNC system can also displayed for maintenance and installation work such as machine parameters, logic diagram of the programmer controller, error messages and diagnostic data.



Fig.1-20 Display Unit for CNC machines (Courtesy of Heidenhain)

1.3 Applications of CNC Machines

CNC machines are widely used in the metal cutting industry and are best used to produce the following types of product:

- Parts with complicated contours
- Parts requiring close tolerance and/or good repeatability
- Parts requiring expensive jigs and fixtures if produced on conventional machines
- Parts that may have several engineering changes, such as during the development stage of a prototype
- In cases where human errors could be extremely costly
- Parts that are needed in a hurry
- Small batch lots or short production runs

Some common types of CNC machines and instruments used in industry are as following:

- Drilling Machine
- Lathe / Turning Centre
- Milling / Machining Centre
- Turret Press and Punching Machine
- Wirecut Electro Discharge Machine (EDM)
- Grinding Machine
- Laser Cutting Machine
- Water Jet Cutting Machine
- Electro Discharge Machine
- Coordinate Measuring Machine
- Industrial Robot

Chapter 2. CNC Part Programming

Objectives:

- ✓ To understand the Dimension Systems in CNC Part Programming.
- ✓ To understand the structure of a CNC Part Programme.
- ✓ To understand the G-codes and other functions of a CNC Part Programme.

2.1 Axis of motion

In generally, all motions have 6 degrees of freedom. In other words, motion can be resolved into 6 axes, namely, 3 linear axes (X, Y and Z axis) and 3 rotational axes (A, B, and C axis).

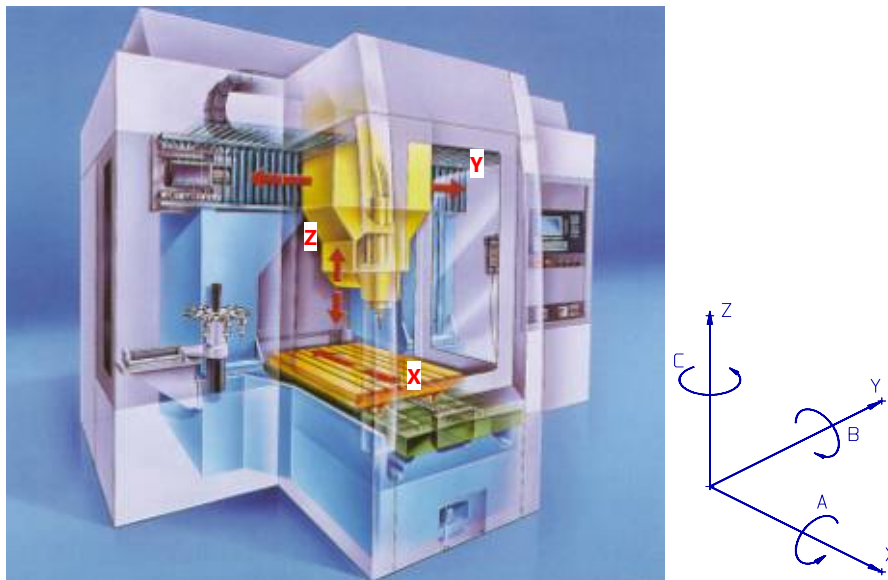

Fig.2-1 Axis of Motion

2.2 Dimension Systems

2.2.1 Incremental System

This type of control always uses as a reference to the preceding point in a sequence of points. The disadvantage of this system is that if an error occurs, it will be accumulated.

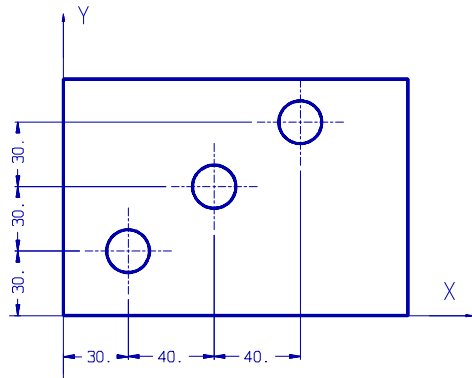

Fig.2-2 Incremental System

2.2.2 Absolute System

In an absolute system all references are made to the origin of the coordinate system. All commands of motion are defined by the absolute coordinate referred to the origin.

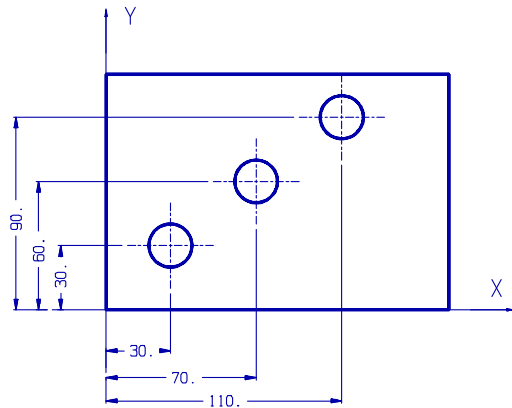

Fig.2-3 Absolute System

2.3 Definition of Programming

NC programming is where all the machining data are compiled and where the data are translated into a language which can be understood by the control system of the machine tool. The machining data is as follows:

- a. Machining sequence classification of process, tool start up point, cutting depth, tool path etc.
- b. Cutting conditions spindle speed, feed rate, coolant, etc.
- c. Selection of cutting tools.

2.4 Programme Structure

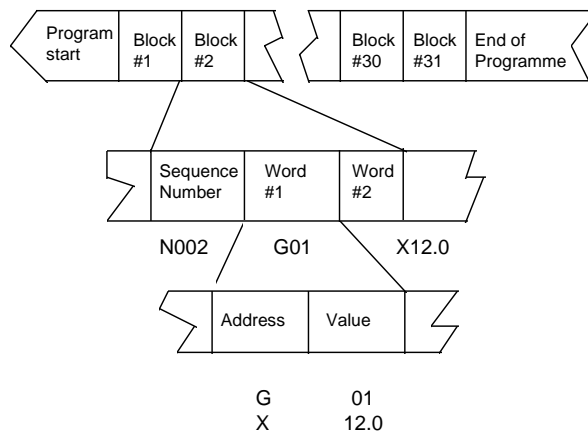

Fig.2-4 Structure of CNC Part Programme

A CNC programme consists of blocks, words and addresses.

a. Block

A command given to the control unit is called a block.

b. Word

A block is composed of one or more words. A word is composed of an identification letter and a series of numerals, e.g. the command for a feed rate of 200mm/min is F200.

c. Address

The identification letter at the beginning of each word is called address. The meaning of the address is in accordance with EIA (Electronic Industries Association) standard RS-274-D. The most common 'addresses' are listed below:

<u>Function</u>	<u>Address</u>
Sequence number	N
Preparatory function	G
Co ordinate word	X, Y, Z
Parameters for Circular Interpolation	I, J, K
Feed function	F
Spindle function	S
Tool function	T
Miscellaneous function	M

An example of a programme is as follows:

```
N20 G01 X20.5 F200 S1000 M03
N21 G02 X30.0 Y40.0 I20.5 J32.0
```

2.5 Explanation of Words

2.5.1 Sequence Number (N Address)

A sequence number is used to identify the block. It is always placed at the beginning of the block and can be regarded as the name of the block. The sequence numbers need not be consecutive. The execution sequence of the programme is according to the actual sequence of the block and not the sequence of the number. In fact some CNC systems do not require sequence numbers.

2.5.2 Preparatory Function (G Address)

A preparatory function determines how the tool is to move to the programmed target. The most common G addresses are listed below:

<u>Code</u>	<u>Function</u>
G00	Point to point position at rapid feed
G01	Linear interpolation
G02	Circular interpolation, clockwise
G03	Circular interpolation, anti clockwise
G40	Cutter compensation cancel
G41	Cutter compensation, Left
G42	Cutter compensation, Right
G45 - G48	Other cutter compensation, if used
G70 - G79	Milling and turning cycle
G80 - G89	Drilling and tapping cycle
G90	Absolute dimensioning
G91	Incremental dimensioning

2.5.3 Co-ordinate Word (X/Y/Z Address)

A co-ordinate word specifies the target point of the tool movement (absolute dimension system) or the distance to be moved (incremental dimension). The word is composed of the address of the axis to be moved and the value and direction of the movement.

Example: *X100 Y-200*
represents the movement to (100, 200). Whether the dimensions are absolute or incremental will have to be defined previously (using G90 or G91).

2.5.4 Parameter for Circular Interpolation (I/J/K Address)

These parameters specify the distance measured from the start point of the arc to the centre. Numerals following I, J and K are the X, Y and Z components of the distance respectively.

2.5.5 Spindle Function (S Address)

The spindle speed is commanded under an S address and is always in revolution per minute. It can be calculated by the following formula:

$$\text{Spindle Speed} = \frac{\text{Surface Cutting Speed (m/min)} \times 1000}{\pi \times \text{Cutter Diameter (mm)}}$$

The following table gives the surface cutting speeds for some common materials:

Cutting tool	Workpiece material			
	Al alloy	Brass	Cast Iron	Mild Steel
HSS	120	75	18	30
Carbide	500	180	120	200

Example: *S2000* represents a spindle speed of 2000rpm

2.5.6 Feed Function (F Address)

The feed is programmed under an F address except for rapid traverse. The unit may be in mm per minute (in the case of milling machine) or in mm per revolution (in the case of turning machine). The unit of the feedrate has to be defined at the beginning of the programme. The feed rate can be calculated by the following formula:

$$\text{Feed Rate} = \text{Chip Load / tooth} \times \text{No of Tooth} \times \text{Spindle Speed}$$

The following table gives the chip load per tooth of milling cutters cutting some common materials:

Milling Cutter	Chip load per tooth (mm/rev)			
	Al alloy	Brass	Cast Iron	Mild Steel
HSS	0.28	0.18	0.20	0.13
Sintered Carbide	0.25	0.15	0.25	0.25

Example: *F200* represents a feed rate of 200mm/min

2.5.7 Tool Function (T Address)

The selection of tool is commanded under a T address.

Example: *T02* represents tool number 2

2.5.8 Miscellaneous Function (M Address)

The miscellaneous function is programmed to control the machine operation other than for co ordinate movement. The most common M functions are as follows:

<u>Code</u>	<u>Function</u>
M00	Programme stop
M03	Spindle rotation clockwise
M04	Spindle rotation counterclockwise
M05	Spindle STOP
M06	Change of Tool
M08	Coolant ON
M09	Coolant OFF
M10	Clamp
M11	Unclamp
M30	Programme end and ready for another start

2.6 Steps for CNC Programming and Machining

The following is the procedures to be followed in CNC programming and machining. The most important point is to verify the programme by test run it on the machine before the actual machining in order to ensure that the programme is free of mistakes.

- a. Study the part drawing carefully.
- b. Unless the drawing dimensions are CNC adapted, select a suitable programme zero point on the work piece. The tool will be adjusted to this zero point during the machine set up.
- c. Determine the machining operations and their sequence.
- d. Determine the method of work clamping (vice, rotary table, fixtures etc).
- e. Select cutting tools and determine spindle speeds and feeds.
- f. Write programme (translate machining steps into programme blocks). If many solutions are possible, try the simplest solution first. It is usually longer, but better to proceed in this way.
- g. Prepare tool chart or diagram, measure tool geometry (lengths, radii) and note.
- h. Clamp work piece and set up machine.
- i. Enter compensation value if necessary.
- j. Check and test programme. It is a good practice to dry run the programme (i) without the workpiece, (ii) without the cutting tools, or (iii) by raising the tool to a safe height.
If necessary, correct and edit programme and check again.
- k. Start machining.

2.7 G-codes in Part Programming

2.7.1 Absolute and Incremental Dimensioning (G90/G91)

G90 and G91 are used to control the dimensioning system that will be used in the data input. In G90 mode, the dimensions will be recognized as absolute while in G91 will be incremental.

2.7.2 Rapid Positioning (G00)

This is to command the cutter to move from the existing point to the target point at the fastest speed of the machine.

Programme Format

G00

X

Y

Z

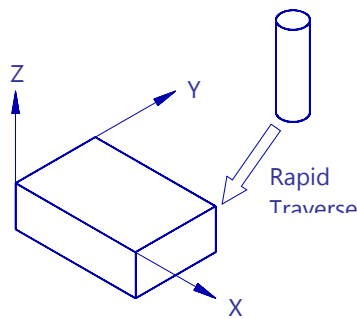

Fig.2-5 Rapid Positioning

2.7.3 Linear Interpolation (G01)

This is to command the cutter to move from the existing point to the target point along a straight line at the speed designated by the F address.

Programme Format

G01

X

Y

Z

F

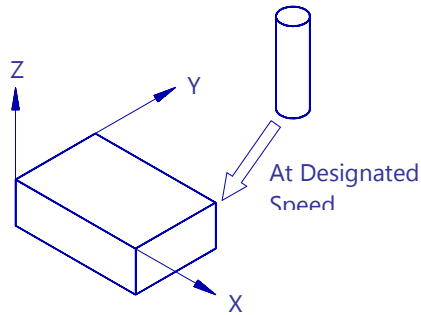

Fig.2-6 Linear Interpolation

2.7.4 Circular Interpolation (G02/G03)

This is to command the cutter to move from the existing point to the target point along a circular arc in clockwise direction (G02) or counterclockwise direction (G03).

In this case, beside the target point, the radius or the centre of the arc is also required. Most of the CNC systems nowadays still require the data of the arc centre rather than the radius.

The parameters of the centre of the circular arc is designated by the I, J and K addresses. I is the distance along the X axis, J along the Y, and K along the Z. This parameter is defined as the vector (magnitude and direction) from the starting point to the centre of the arc.

Programme Format
(Clockwise Direction)

```
G02
X
Y
I (XC - XS)
J (YC - YS)
```

Where

X_C and Y_C is the coordinate of the centre, and

X_S and Y_S is the coordinate of the start point of the arc.

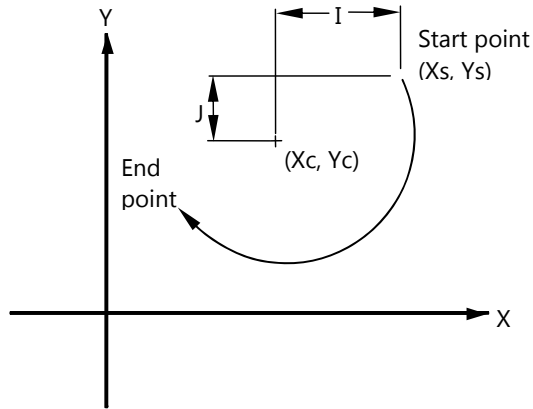

Fig.2-7 Circular Interpolation - Clockwise

Programme Format
(Counterclockwise Direction)

```
G03
X
Y
I
J
```

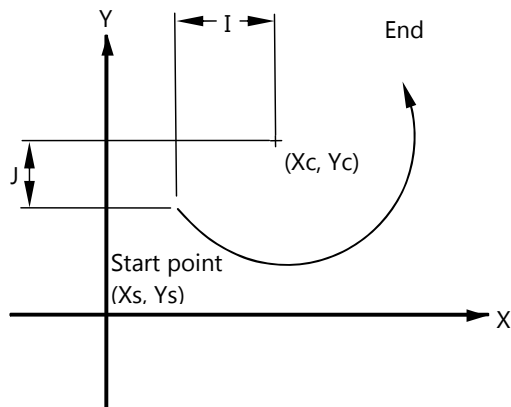

Fig.2-8 Circular Interpolation - Counterclockwise

2.7.5 Cutter Compensation (G40/G41/G42)

In CNC machining, if the cutter axis is moving along the programmed path, the dimension of the workpiece obtained will be incorrect since the diameter of the cutter has not been taken into account.

Modern CNC systems are capable of doing this type of calculation which is known as cutter compensation. What the system requires are the programmed path, the cutter diameter and the position of the cutter with reference to the contour. Normally, the cutter diameter is not included in the programme. It has to be input to the CNC system in the tool setting process.

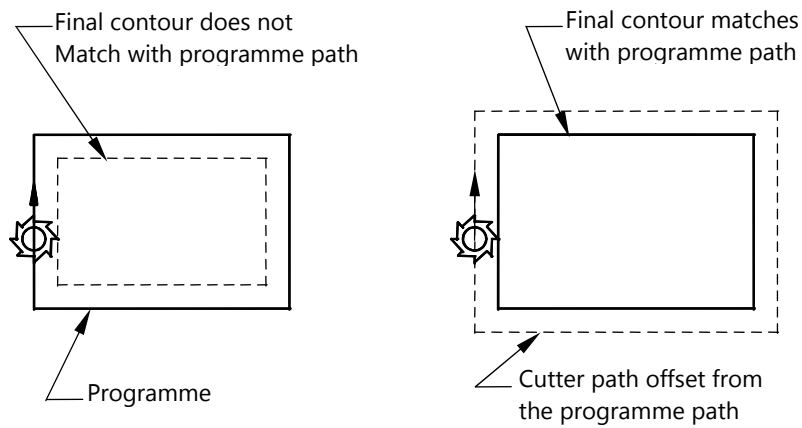

Fig.2-9 Comparison of Tool Path with and without Cutter Compensation

If the cutter is on the left of the contour, G41 is used. If the cutter is on the right of the contour, G42 will be used. G40 is to cancel the compensation calculation.

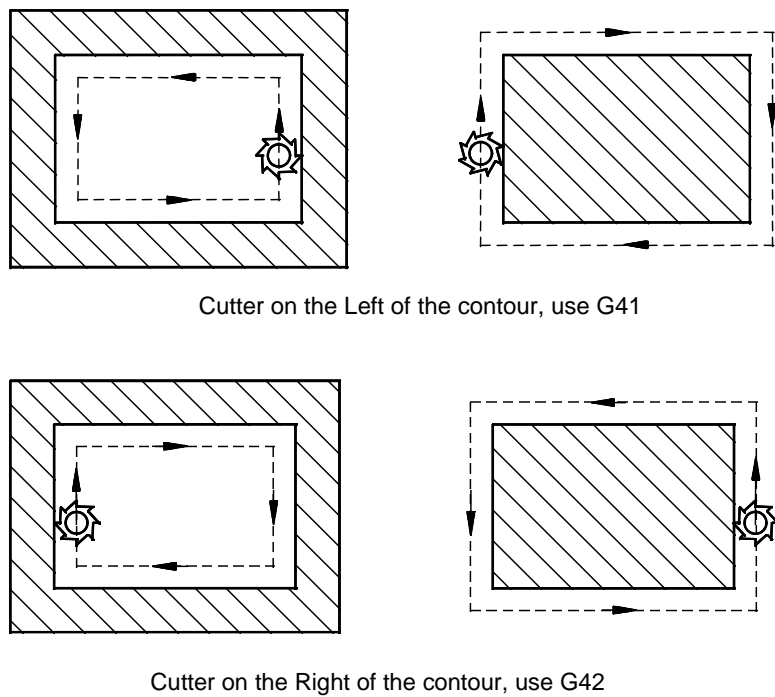
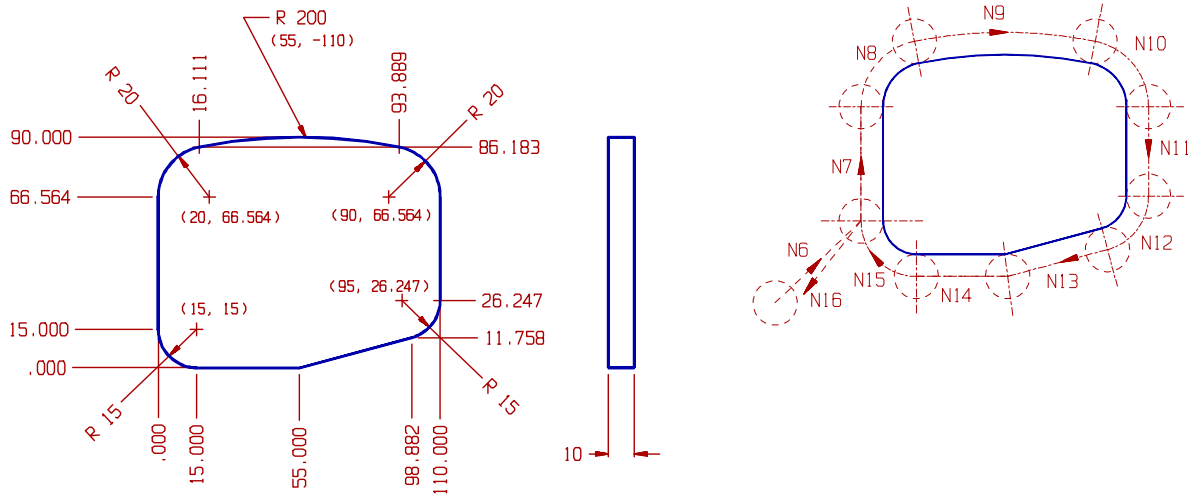

Fig.2-10 Direction of Cutter Compensation

Programme Example 1



Programme

Explanation

N01	G90		Absolute Dimensioning
N02	G00	X-30 Y-30 Z100	Rapid move to (X-30, Y-30, Z100)
N03	T01		Using Tool Number 1
N04	G00	Z5 S1000 M03	Rapid move to Z5; start spindle clockwise at 1000rpm
N05	G01	Z-10 F100	Feed to Z-10 at 100mm/min
N06	G41 G01	X0 Y15 F200	Call up compensation, cutter on the left feed to (X0, Y15) at 200mm/min
N07	G01	Y66.564	From N07 to N15 is the contour cutting
N08	G02	X16.111 Y86.183 I20 J0	
N09	G02	X93.889 Y86.183 I38.889 J-196.183	
N10	G02	X110 Y66.564 I-3.889 J-19.619	
N11	G01	Y26.247	
N12	G02	X98.882 Y11.758 I-15 J0	
N13	G01	X55 Y0	
N14	G01	X15	
N15	G02	X0 Y15 I0 J15	

N16	G40	X-30 Y-30	Cancel of compensation; feed to (X-30, Y-30)
N17	G00	Z100 M30	Rapid move to Z100; programme end

Programming Example 2

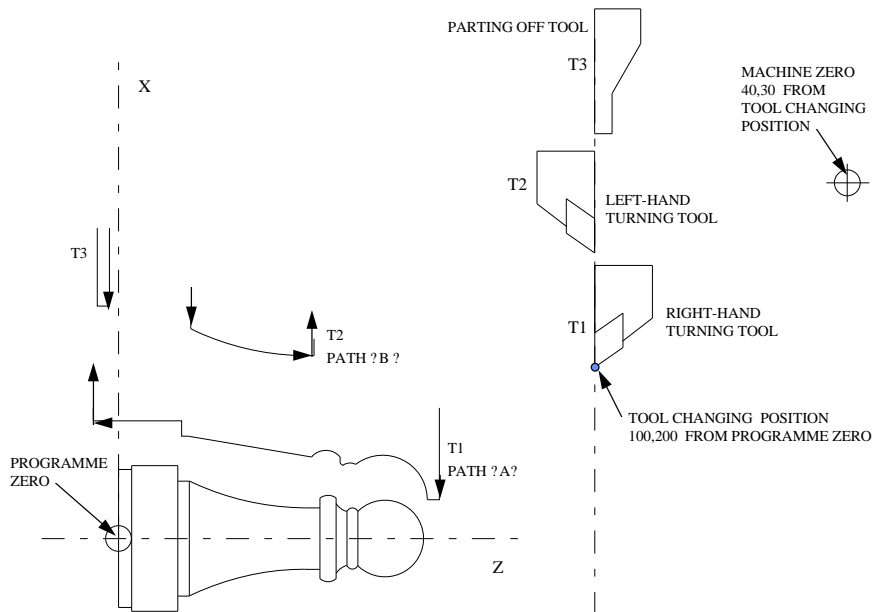

<u>Programme</u>	<u>Explanation</u>
N01 G28 U0.1 W0.1;	Return to Machine Zero
N02 G00 U-60.0 W-40.0;	Rapid move to Tool Changing position
N03 G50 X200.0 Z100.0;	Assign the Programme Zero
N04 G97 S2000;	Assign revolution speed as 2000 rpm
N05 M03;	Switch on spindle, turning in forward direction
N06 T0101;	Select Tool Number T1 and call tool offset
N07 G00 X0 Z42.0;	Rapid move to (X0, Z42.0)
N08 M08;	Switch coolant on
N09 G69 F0.15;	Assign feed to be 0.15 mm/rev
N10 G01 Z40.45;	Start cutting the Contour along path A
N11 G03 X 9.217 Z31.13 R5.8;	
N12 X8.955 Z29.465 R1.556;	
N13 G02 X 9.6 Z29.1 R1.48;	
N14 G01 X11.142;	

N15	G03	X 11.142 Z25.4 R2.398;	
N16	G01	X16.6 Z9.385;	
N17	Z8.5;		
N18	X20.6;		
N19	Z-3.0;		Finish Contouring
N20	G00	X200.0 Z100.0;	Rapid move to Tool Changing Position
N21	T0100;		Cancel tool offset
N22	T0202;		Select Tool Number T2 and call tool offset
N23	G00	X21.0 Z9.385;	Rapid move to (X21.0 Z3.985)
N24	G01	X16.6 F0.15;	Start cutting contour along path B, in 0.15mm/rev feed
N25	G03	X9.6 Z24.203 R34.2;	
N26	G01	Z25.4;	
N27	X14.0;		Finish contouring
N28	G00	X200.0 Z100.0;	Rapid move to Tool Changing position
N29	T0200;		Cancel tool offset
N30	T0303;		Select Tool Number T3 and call tool offset
N31	G00	X24.0 Z0;	Rapid move to (X24.0 Z0)
N32	G01	X-0.5 F0.06;	Part off in feedrate 0.06 mm/rev
N33	G00	X200.0 Z100.0;	Rapid move to Tool Changing position
N34	T0300;		Cancel tool offset;
N35	M30;		Programme end

2.7.6 Other Functions

Modern CNC systems have some specially designed functions to simplify the manual programming. However, since most of these functions are system oriented, it is not intended to discuss them here in detail. The following paragraphs give a brief description of commonly used functions in modern CNC systems. The user should refer to the programming manuals of the machine for the detail programming and operation.

a. Mirror Image

This is the function that converts the programmed path to its mirror image, which is identical in dimensions but geometrically opposite about one or two axes.

b. Programme Repetition and Looping

In actual machining, it is not always possible to machine to the final dimension in one go. This function enables the looping of a portion of the programme so that the portion can be executed repeatedly.

c. Pocketing Cycle

Pocketing is a common process in machining. This is to excavate the material within a boundary normally in zigzag path and layer by layer. In a pocketing cycle, the pattern of cutting is pre-determined. The user is required to input parameters including the length, width and depth of the pocket, tool path spacing, and layer depth. The CNC system will then automatically work out the tool path.

d. Drilling, Boring, Reaming and Tapping Cycle

This is similar to pocketing cycle. In this function, the drilling pattern is pre-determined by the CNC system. What the user has to do is to input the required parameters such as the total depth of the hole, the down feed depth, the relief height and the dwell time at the bottom of the hole.

Chapter 3. Computer Aided Manufacturing

Objectives:

- ✓ To understand the flow of a Computer Aided Manufacturing System.
- ✓ To understand the characteristics of the process Tool Motion Definition in a CAM system.
- ✓ To understand the characteristics of the process Data Transmission in a CAM system.

3.1 Computer Aided Part Programming

In manual preparation of a CNC part programme, the programmer is required to define the machine or the tool movement in numerical terms. If the geometry is complicated 3D surfaces cannot be programmed manually.

Over the past years, lot of effort is devoted to automate the part programme generation. With the development of the CAD/CAM system, interactive graphic system is integrated with the CNC part programming. Graphic based software using menu driven technique improves the user friendliness. The part programmer can create the geometrical model in the CAM package or directly extract the geometrical model from the CAD/CAM data base. Built in tool motion commands can assist the part programmer to calculate the tool paths automatically. The part programmer can verify the tool paths through the graphic display using the animation function of the CAM system. It greatly enhances the speed and accuracy in tool path generation.

3.2 Flow of A Computer Aided Manufacturing System

There are several computer aided manufacturing or CAD/CAM system available in the market. Their basic features can be summarized below:

- a. Geometric Modeling / CAD Interface
- b. Tool Motion definition
- c. Data Processing
- d. Post Processing
- e. Data Transmission

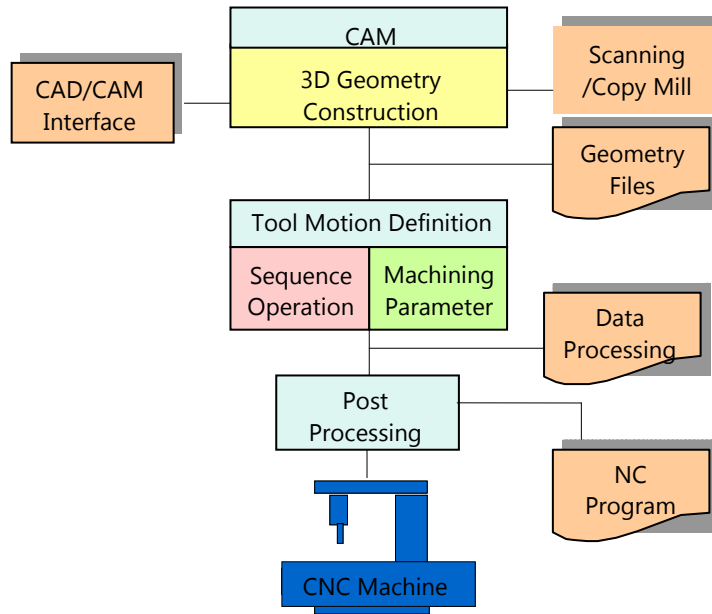

Fig.3-1 Flow Chart of a CAM System

3.2.1 Geometric Modeling / CAD Interface

The geometry of the workpiece can be defined by basic geometrical elements such as points, lines, arcs, splines or surfaces. The two dimensional or three dimensional geometrical elements are stored in the computer memory in forms of a mathematical model. The mathematical model can be a wire frame model, a surface model, or a solid model.

In addition, the geometric models can be imported from other CAD/CAM system through standard CAD/CAM interface formats such as Initial Graphic Exchange Specification (IGES). Initial Graphic Exchange Specification (IGES)

IGES is a graphic exchange standard jointly developed by industry and the National Bureau of Standards with the support of the U.S. Air Force. It provides transportability of 3-dimensional geometry data between different systems. Throughout this system, geometrical elements from one system can be translated into a neutral file standard and then from this standard into other format.

3.2.2 Tool Motion Definition

After the geometric modeling, machining data such as the job setup, operation setup and motion definition are input into the computer to produce the cutting location file (CL file) for machining the workpiece.

a. Job setup

This is to input the machine datum, home position, and the cutter diameters for the CL file.

b. Operation setup

This is to input into the system the operation parameters such as the feed rate, tolerance, and approach / retract planes, spindle speed, coolant ON/OFF, stock offset and the tool selection etc.

c. Motion definition

Built in machining commands are used to control the tool motion to machine the products. This includes the hole processing, profile machining, pocketing, surface machining, gouge checking, etc.



Fig.3-2 CAM System

3.2.3 Data Processing

The input data is translated into computer usable format. The computer will process the desired part surface, the cutter offset surface and finally compute the paths of the cutter which is known as the cutter location data file (CL file). The tool paths can normally be animated graphically on the display for verification purpose.

Furthermore, production planning data such as tool list, set up sheet, and machining time is also calculated for users' reference.

3.2.4 Post Processing

Different CNC machines have different features and capabilities, the format of the CNC program may also vary from each other. A process is required to change the general instructions from the cutter location file to a specific format for a particular machine tool and this process is called post processing.

Post processor is a computer software which converts the cutter location data files into a format which the machine controller can interpret correctly. Generally, there are two types of post processor.

a. Specific Post Processor

This is a tailor-made software which output the precise code for a specific CNC machine. The user is not required to change anything in the programme.

b. Generic (Universal) Post Processor

This is a set of generalized rules which needs the user to customize into the format that satisfies the requirements of a specific CNC machine.

3.2.5 Data Transmission

After post processing, the CNC programme can be transmitted to the CNC machines either through the off line or on line process.

a. Off Line Processes

Data carriers are used to transmit the CNC programme to the CNC machines. It includes paper tapes, magnetic tape or magnetic disc.

b. On Line Processes

On line processes is commonly used in DNC operation and data is transferred either serially or parallel using data cables.

Serial Transmission

Asynchronous serial transmission is most widely used in data transmission and RS232C is the most popular asynchronous standard. Built in RS232C serial port (9 pins or 25 pins) is available in many computers. RS232C is inexpensive; easy to program and with a baud rate up to 38400. However, its noise margin is limited up to 15 meters.

Parallel Transmission

Parallel transmission is commonly used in data transmission between computers and external devices such as sensors, programmable logic controllers (PLC) or actuators. One common standard is IEEE488. It contains a 24 lines bus with 8 for data, 8 for controls and 8 for ground. It can transfer data up to 1 Mbps for a 20-meter cable.

Local Area Networks

To enable the CAD/CAM facilities to run smoothly, it is desirable for the facilities to be linked together. In the local-area network, terminals can access any computer on the network or devices on the shop floor without a physical hardwire with speed up to 300

megabits per second. For instance, Ethernet runs at 100Mbps which is much faster than an RS232 serial communication (115.2kbps).

A LAN consists of both software and hardware design, which governed by a set of rules called protocol. The design of software enable controls of data handling and error recovery, while hardware generates and receives signals, and media that carries the signals. The protocol defines the logical, electrical, and physical specifications of the network. The same protocol must be followed in order to have an effective communication with each other in the network.

References

- Computer Numerical Control of Machine Tools, G.E.Thyer, Heinemann Professional Publishing 1988
- The CNC Workshop, Frank Nanfara, Tony Uccello, Derek Murphy, Prentice-Hall 2002
- CNC Programming, Michael Mattson, Delmar Cengage Learning, 2010
- The Machining of Metals, Armsregio E. J. A., R. H. Brown, Englewood Cliffs, N.J., Prentice-Hall 1969
- Managing Computer Numerical Control Operations, Mike Lynch, Society of Manufacturing Engineers 1995
- International Standard ISO2806 Industrial Automation System – Numerical Control of Machines – Vocabulary, International Organization for Standardization